

2003 Saab 9.3 Sedan and 2004 Saab 9.3 All Model Parking Brake Update

Recently there has been an increase in service requests by owners of 2003 Saab 9.3 Sedan models and 2004 Saab 9.3 model vehicles for parking brakes that will not release. It was first thought that this increase in occurrences was due to the parking brake freezing on these vehicles as most of the requests were coming in from the Northeast United States during times of sub-freezing temperatures. After some investigation it was discovered that the condition is due to a piece in the parking brake release mechanism that fails, not allowing the parking brake to be released in the conventional manner.

AAA discussed this problem with a Saab dealer technician, who checked the recommendations in the Saab factory technical service bulletins for releasing the stuck parking brake. AAA has developed the following procedures that might help release the parking brake before transporting it to the dealership for proper repair of the parking brake assembly. The problem is easily identified, as a properly functioning parking brake handle will point toward the radio area of the dash when applied and one with the problem described above will most times point toward the top of the windshield when applied.

NOTE: Saab wants these vehicles transported to the dealership for repair regardless of the success of the following steps to release the parking brake due to safety concerns.

1. Start the vehicle up and pump the brake pedal 3 times. On the third application, hold the brake pedal down firmly. Grasp the parking brake handle in one hand; pull up slightly on it while depressing the parking brake handle release button with your other hand. The parking brake may release, allowing the vehicle to be loaded for towing.
2. If the above method does not work and the vehicle has an automatic transmission, start the vehicle up, depress the brake pedal and shift the transmission into drive or reverse depending on the clearance between the disabled vehicle and other objects. Grasp the parking brake handle in one hand; pull up slightly on it while depressing the parking brake handle release button with your other hand. Pump the brake pedal quickly 3 times ensuring that the vehicle will not contact any object around it while attempting to release the parking brake. Try the same procedure with the transmission in the opposite gear if room permits.
3. If methods 1 and 2 are not successful, proceed as follows. This method requires the use of some basic hand tools and removal of parts of the center console area around the parking brake handle.
 - Open console armrest lid

- Remove coin holder.
- Using a 13mm (1/2") socket, loosen parking brake adjusting nut by turning it counter-clockwise until parking brakes are released.
- Vehicle may be towed to nearest Saab dealer for repairs.
- DO NOT return vehicle to owner in this condition, only transport to dealer for proper repair of parking brake mechanism.
- Notify Saab dealer that parking brake cable needs to be properly adjusted before returning the car to owner.

The image below shows the position of the adjusting nut in the center console area.

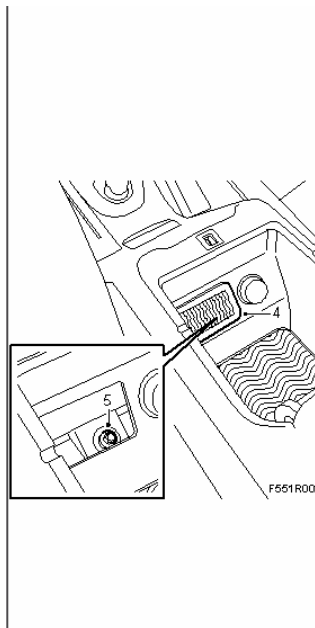

This information is provided with the permission of Saab, and is provided as a courtesy to the industry. If you have any questions or comments about the above procedures, feel free to contact the AAA National Technical Training and Research department: 407-444-8041 or at ljohnnes@national.aaa.com